

INSTRUCTION MANUAL

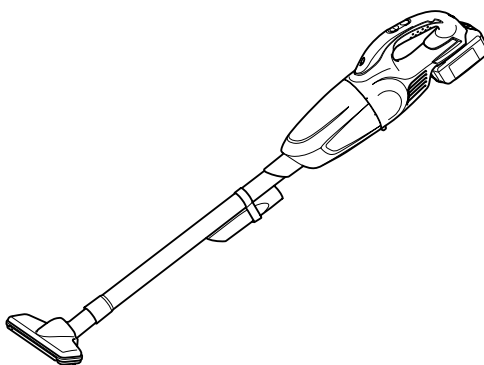

# Cordless Cleaner

## DCL181F



Read before use.

# WARNING

This appliance can be used by children aged from 8 years and above and persons with reduced physical, sensory or mental capabilities or lack of experience and knowledge if they have been given supervision or instruction concerning use of the appliance in a safe way and understand the hazards involved. Children shall not play with the appliance. Cleaning and user maintenance shall not be made by children without supervision.

# SPECIFICATIONS

<b>Model:</b>		<b>DCL181F</b>	
Capacity		650 mL	
Continuous use (with battery BL1830B)	HIGH	Approx. 20 min	
	LOW	Approx. 40 min	
Overall length		999 mm	
Rated voltage		D.C. 18 V	
Battery cartridge		BL1815N, BL1820, BL1820B	BL1830, BL1830B, BL1840, BL1840B, BL1850, BL1850B, BL1860B
Net weight		1.2 kg	1.4 kg

- Due to our continuing program of research and development, the specifications herein are subject to change without notice.
- Specifications and battery cartridge may differ from country to country.
- Weight, with battery cartridge, according to EPTA-Procedure 01/2003

# Symbols

The following show the symbols used for the equipment. Be sure that you understand their meaning before use.



Read instruction manual.



Only for EU countries  
Do not dispose of electric equipment or battery pack together with household waste material! In observance of the European Directives, on Waste Electric and Electronic Equipment and Batteries and Accumulators and Waste Batteries and Accumulators and their implementation in accordance with national laws, electric equipment and batteries and battery pack(s) that have reached the end of their life must be collected separately and returned to an environmentally compatible recycling facility.

# Intended use

The tool is intended for collecting dry dust.

# SAFETY WARNINGS

## Cordless cleaner safety warnings

**⚠ WARNING: IMPORTANT! READ CAREFULLY all safety warnings and all instructions BEFORE USE.** Failure to follow the warnings and instructions may result in electric shock, fire and/or serious injury.

1. Do not expose to rain. Store indoors.
2. Do not allow to be used as a toy. Close attention is necessary when used by or near children.
3. Use only as described in this manual. Use only manufacturer's recommended attachments.
4. Do not use with damaged battery. If appliance is not working as it should, has been dropped, damaged, left outdoors, or dropped into water, return it to a service center.
5. Do not handle appliance with wet hands.
6. Do not put any object into openings. Do not use with any opening blocked; keep free of dust, lint, hair, and anything that may reduce air flow.
7. Keep hair, loose clothing, fingers, and all parts of body away from openings and moving parts.
8. Turn off all controls before removing the battery.

9. Use extra care when cleaning on stairs.
10. Do not use to pick up flammable or combustible liquids, such as gasoline, or use in areas where they may be present.
11. Use only the charger supplied by the manufacturer to recharge.
12. Do not pick up anything that is burning or smoking, such as cigarettes, matches, or hot ashes.
13. Do not use without dust bag and/or filters in place.
14. Do not charge the battery outdoors.
15. Recharge only with the charger specified by the manufacturer. A charger that is suitable for one type of battery pack may create a risk of fire when used with another battery pack.
16. Use power tools only with specifically designated battery packs. Use of any other battery packs may create a risk of injury and fire.
17. When (the) battery pack is not in use, keep it away from other metal objects, like paper clips, coins, keys, nails, screws or other small metal objects, that can make a connection from one terminal to another.
18. Under abusive conditions, liquid may be ejected from the battery; avoid contact. If contact accidentally occurs, flush with water.

## SAVE THESE INSTRUCTIONS.

### ADDITIONAL SAFETY RULES

This appliance is intended for household use.

1. Read this instruction manual and the charger instruction manual carefully before use.
2. Do not pick up the following materials:
  - Hot materials such as lit cigarettes or spark/metal dust generated by grinding/cutting metal
  - Flammable materials such as gasoline, thinner, benzine, kerosene or paint
  - Explosive materials like nitroglycerin
  - Ignitable materials such as Aluminum, zinc, magnesium, titanium, phosphorus or celluloid
  - Wet dirt, water, oil or the like
  - Hard pieces with sharp edges, such as wood chips, metals, stones, glasses, nails, pins or razors
  - Powder to clot such as cement or toner
  - Conductive dust such as metal or carbon
  - Fine particle like concrete dust

Such action may cause fire, injury and/or property damage.
3. Stop operation immediately if you notice anything abnormal.
4. If you drop or strike the cleaner, check it carefully for cracks or damage before operation.
5. Do not bring close to stoves or other heat sources.
6. Do not block the intake hole or vent holes.

## SAVE THESE INSTRUCTIONS.

### Important safety instructions for battery cartridge

1. Before using battery cartridge, read all instructions and cautionary markings on (1) battery charger, (2) battery, and (3) product using battery.
2. Do not disassemble battery cartridge.
3. If operating time has become excessively shorter, stop operating immediately. It may result in a risk of overheating, possible burns and even an explosion.
4. If electrolyte gets into your eyes, rinse them out with clear water and seek medical attention right away. It may result in loss of your eyesight.
5. Do not short the battery cartridge:
  - (1) Do not touch the terminals with any conductive material.
  - (2) Avoid storing battery cartridge in a container with other metal objects such as nails, coins, etc.
  - (3) Do not expose battery cartridge to water or rain. A battery short can cause a large current flow, overheating, possible burns and even a breakdown.
6. Do not store the tool and battery cartridge in locations where the temperature may reach or exceed 50 °C (122 °F).
7. Do not incinerate the battery cartridge even if it is severely damaged or is completely worn out. The battery cartridge can explode in a fire.
8. Be careful not to drop or strike battery.
9. Do not use a damaged battery.
10. The contained lithium-ion batteries are subject to the Dangerous Goods Legislation requirements. For commercial transports e.g. by third parties, forwarding agents, special requirement on packaging and labeling must be observed. For preparation of the item being shipped, consulting an expert for hazardous material is required. Please also observe possibly more detailed national regulations. Tape or mask off open contacts and pack up the battery in such a manner that it cannot move around in the packaging.
11. Follow your local regulations relating to disposal of battery.

## SAVE THESE INSTRUCTIONS.

**CAUTION:** Only use genuine Makita batteries. Use of non-genuine Makita batteries, or batteries that have been altered, may result in the battery bursting causing fires, personal injury and damage. It will also void the Makita warranty for the Makita tool and charger.

### Tips for maintaining maximum battery life

1. Charge the battery cartridge before completely discharged. Always stop tool operation and charge the battery cartridge when you notice less tool power.
2. Never recharge a fully charged battery cartridge. Overcharging shortens the battery service life.
3. Charge the battery cartridge with room temperature at 10 °C - 40 °C (50 °F - 104 °F). Let a hot battery cartridge cool down before charging it.

## FUNCTIONAL DESCRIPTION

**CAUTION:** Always be sure that the tool is switched off and the battery cartridge is removed before adjusting or checking function on the tool.

**CAUTION:** Take care not to trap finger(s) between cleaner and battery as shown in diagram when loading battery. Trapping finger(s) may cause injury.

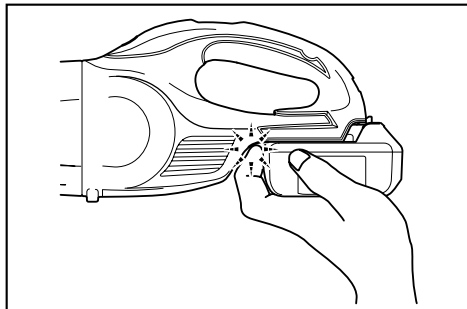

## Installing or removing battery cartridge

**CAUTION:** Always switch off the tool before installing or removing of the battery cartridge.

**CAUTION:** Hold the tool and the battery cartridge firmly when installing or removing battery cartridge. Failure to hold the tool and the battery cartridge firmly may cause them to slip off your hands and result in damage to the tool and battery cartridge and a personal injury.

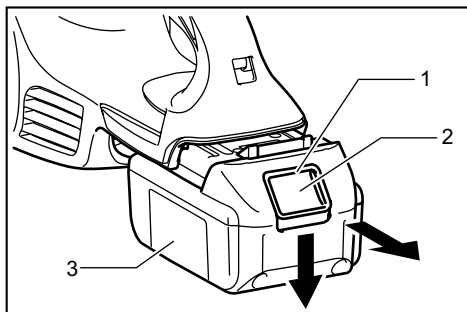

► 1. Red indicator 2. Button 3. Battery cartridge

To remove the battery cartridge, slide it from the tool while sliding the button on the front of the cartridge.

To install the battery cartridge, align the tongue on the battery cartridge with the groove in the housing and slip it into place. Insert it all the way until it locks in place with a little click. If you can see the red indicator on the upper side of the button, it is not locked completely.

**CAUTION:** Always install the battery cartridge fully until the red indicator cannot be seen. If not, it may accidentally fall out of the tool, causing injury to you or someone around you.

**CAUTION:** Do not install the battery cartridge forcibly. If the cartridge does not slide in easily, it is not being inserted correctly.

## Battery protection system

### Lithium-ion battery with star marking

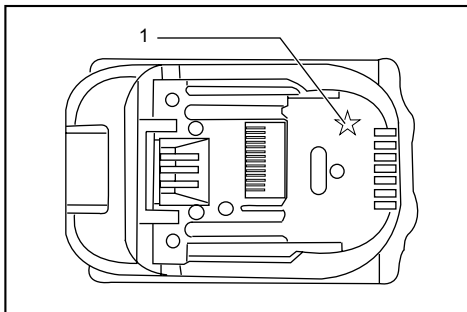

► 1. Star marking

Lithium-ion batteries with a star marking are equipped with a protection system. This system automatically cuts off power to the tool to extend battery life. The tool will automatically stop during operation if the tool and/or battery are placed under one of the following conditions:

#### Overloaded:

The tool is operated in a manner that causes it to draw an abnormally high current.

In this situation, turn the tool off and stop the application that caused the tool to become overloaded. Then turn the tool on to restart.

If the tool does not start, the battery is overheated. In this situation, let the battery cool before turning the tool on again.

#### Low battery voltage:

The remaining battery capacity is too low and the tool will not operate. In this situation, remove and recharge the battery.

## Indicating the remaining battery capacity

### Only for battery cartridges with the indicator

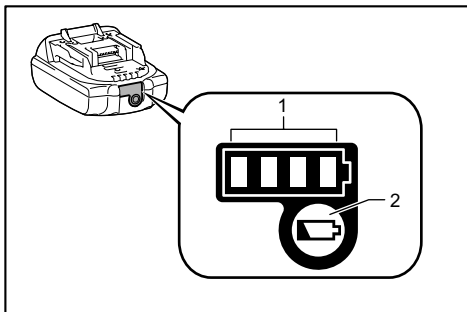

► 1. Indicator lamps 2. Check button

Press the check button on the battery cartridge to indicate the remaining battery capacity. The indicator lamps light up for few seconds.

Indicator lamps			Remaining capacity
Lighted	Off	Blinking	
■	■ ■ ■ ■		75% to 100%
■	■ ■ ■ □		50% to 75%
■	■ ■ □ □		25% to 50%
■	□ □ □ □		0% to 25%
▬	□ □ □ □		Charge the battery.
■ ■ □ □	□ □ ■ ■	↑ ↓	The battery may have malfunctioned.

**NOTE:** Depending on the conditions of use and the ambient temperature, the indication may differ slightly from the actual capacity.

## Switch action

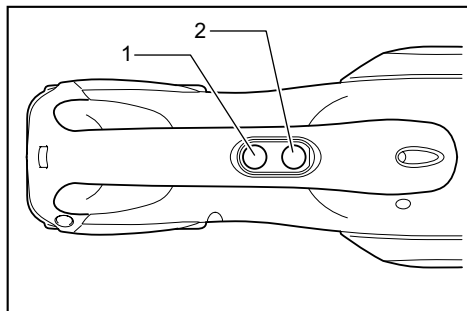

► 1. OFF button 2. HIGH/LOW button

To start the cleaner, simply press the "HIGH/LOW" button. To switch off, press the "OFF" button. To change the cleaner speed, press the "HIGH/LOW" button. The first press on this button is for high speed and the second press for low speed and then each press on this button repeats the high/low speed cycle alternatively.

## Lighting the lamp

**CAUTION:** Never look into the light directly. Direct light causes damage to your eyes.

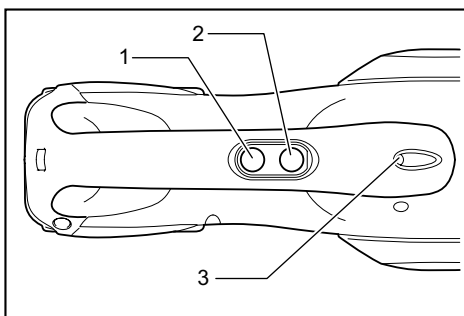

► 1. OFF button 2. HIGH/LOW button 3. Lamp

To turn on the lamp, simply press the "HIGH/LOW" button. To turn off the lamp, press the "OFF" button.

## ASSEMBLY

**CAUTION:** Always be sure that the tool is switched off and the battery cartridge is removed before carrying out any work on the tool.

### Type of filter

#### Normal filter

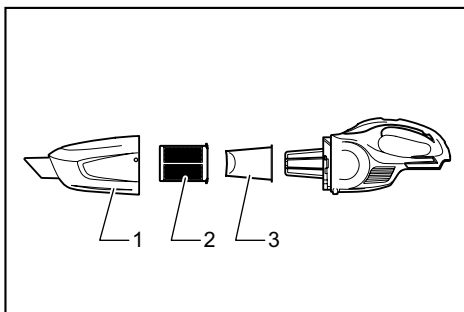

► 1. Capsule 2. Prefilter 3. Filter

#### High performance filter

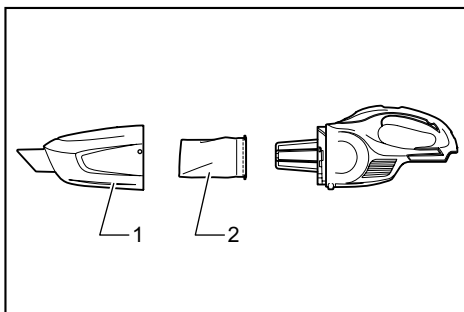

► 1. Capsule 2. High performance filter

## Disposing of dust

**CAUTION:** Empty the cleaner before it becomes too full, or the suction force weakens.

**CAUTION:** Be sure to empty out the dust inside the cleaner itself. Failure to do so may cause the filter to be clogged or the motor to be damaged.

### Disposing of dust for normal filter

1. In order to drop dust sticking on the filter in the capsule, tap the capsule 4 or 5 times with your hand. Now point suction inlet downwards, turn capsule in direction of arrow in diagram, and disconnect capsule slowly and straight.

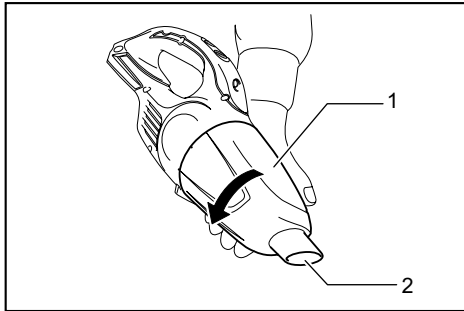

► 1. Capsule 2. Suction inlet

**NOTE:** Dust may spill out when capsule is opened, so be sure to set a garbage bag beneath capsule.

2. Remove accumulated dust from inside of capsule and off of prefilter.

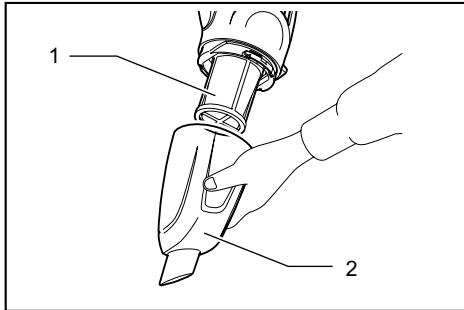

► 1. Prefilter 2. Capsule

3. Twist prefilter in direction of arrow to unfasten securing lip from cleaner unit and then pull off prefilter.

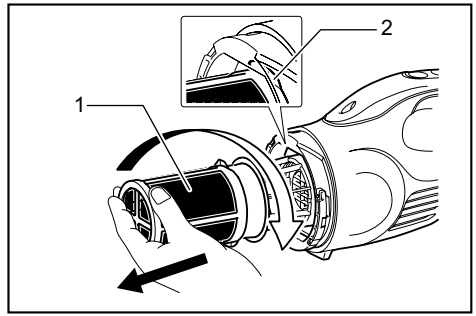

► 1. Prefilter 2. Securing lip

4. Clean out fine dust from prefilter. Next, remove filter, and lightly tap to dislodge dust.

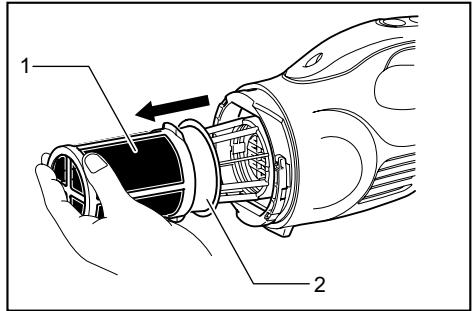

► 1. Prefilter 2. Filter

### Disposing of dust for high performance filter

1. In order to drop dust sticking on the filter in the capsule, tap the capsule 4 or 5 times with your hand. Now point suction inlet downwards, turn capsule in direction of arrow in diagram, and disconnect capsule slowly and straight.

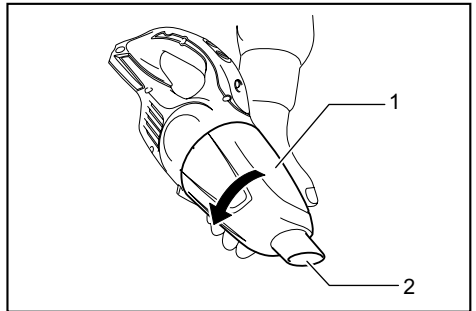

► 1. Capsule 2. Suction inlet

**NOTE:** Dust may spill out when capsule is opened, so be sure to set a garbage bag beneath capsule.

2. Remove accumulated dust from inside of capsule and off of high performance filter.

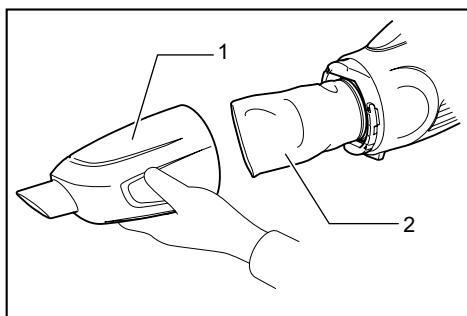

► 1. Capsule 2. High performance filter

3. Twist high performance filter in direction of arrow to unfasten securing lip from cleaner unit and then pull off the filter.

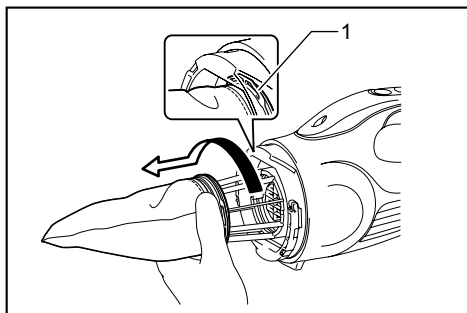

► 1. Securing lip

4. Clean out the fine dust and lightly tap to dislodge dust from high performance filter.

## Reassembly

### Reassembly for normal filter

1. Put on filter until it is fully in position on the cleaner unit.

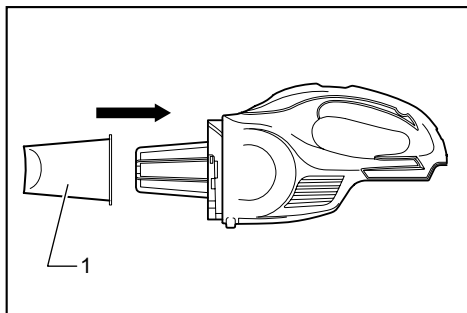

► 1. Filter

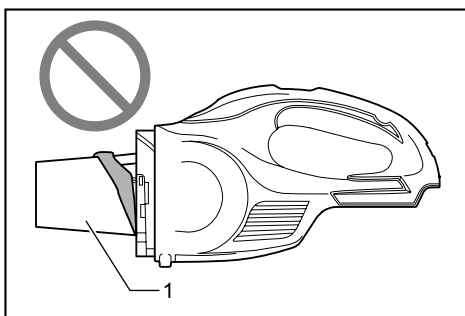

► 1. Filter

**NOTE:** Make sure filter is put on straight without being peeled back. If filter is put on incorrectly as shown in diagram, dust will get into motor housing, and cause motor failure.

2. Connect prefilter. At this time, make sure to twist prefilter so that securing lip is firmly locked into cleaner unit.

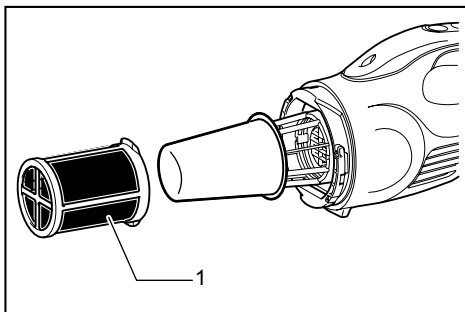

► 1. Prefilter

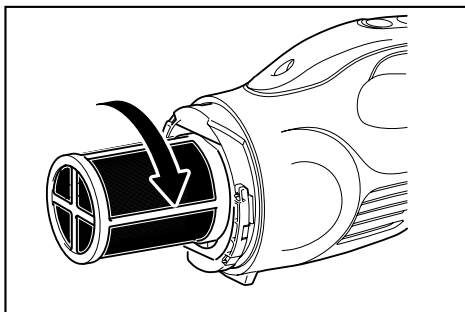

3. Connect capsule. Align O symbol on capsule with O symbol on handle and then firmly twist capsule in direction of arrow until it is secured.

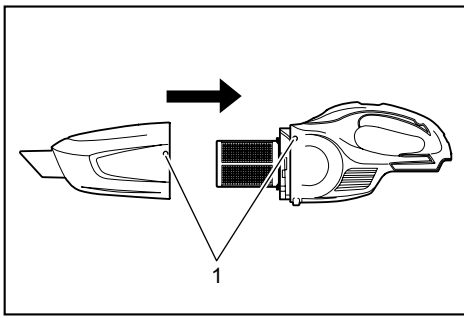

► 1. O Mark

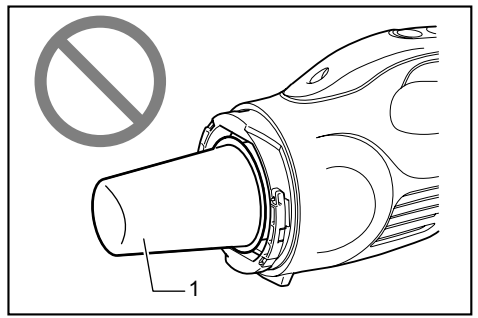

► 1. Filter

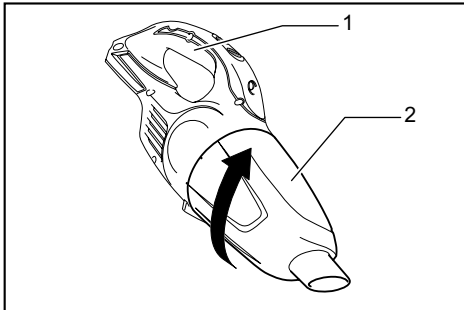

► 1. Handle 2. Capsule

Example 3: Filter has been loaded in a peeled back state

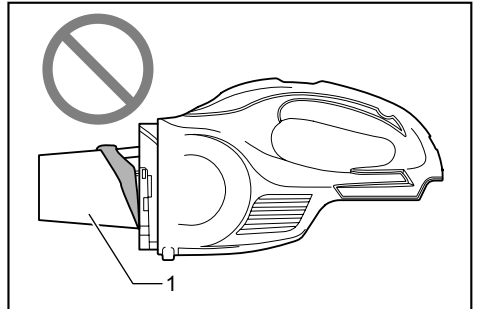

► 1. Filter

**NOTE:** Always remove dust ahead of time, as suction power will be reduced if there is too much dust in cleaner.

**NOTE:** Always be sure to check that both filter and prefilter are loaded correctly prior to using cleaner. If they are not loaded correctly, dust will get into the motor housing, and cause motor failure. If the following examples occur, filter and prefilter are not loaded correctly. Reload them correctly to rectify problem.

### Problem Examples

Example 1: Only prefilter has been loaded (no filter)

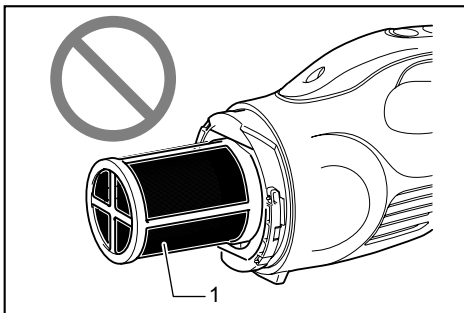

► 1. Prefilter

Example 2: Only filter has been loaded (no prefilter)

Example 4: Prefilter's securing lip is not firmly locked into groove of cleaner housing

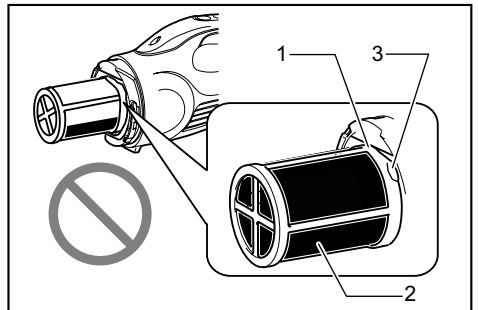

► 1. Groove of cleaner housing 2. Prefilter 3. Securing lip

### Reassembly for high performance filter

1. Connect high performance filter. At this time, make sure to twist high performance filter so that securing lip is firmly locked into cleaner unit.



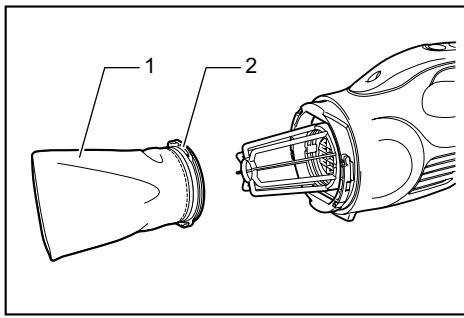

► 1. High performance filter 2. Securing lip

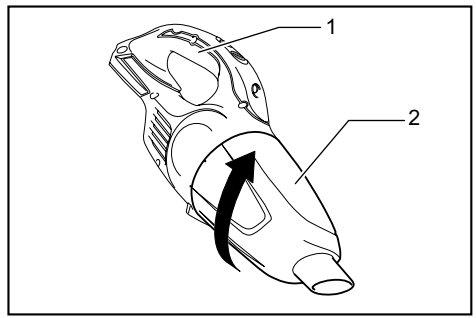

► 1. Handle 2. Capsule

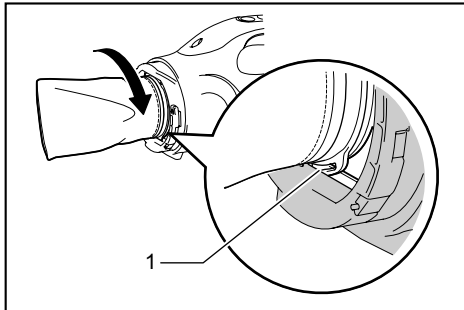

► 1. Securing lip

2. Connect capsule. Align O symbol on capsule with O symbol on handle and then firmly twist capsule in direction of arrow until it is secured.

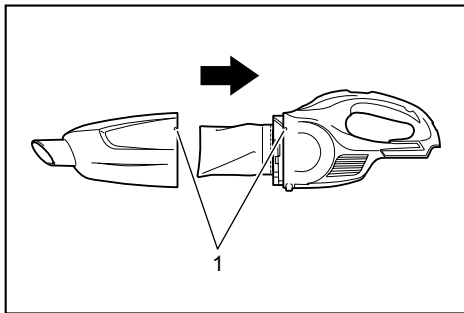

► 1. O Mark

**NOTE:** Always remove dust ahead of time, as suction power will be reduced if there is too much dust in cleaner.

**NOTE:** Always be sure to check that high performance filter is loaded correctly prior to using cleaner. If they are not loaded correctly, dust will get into the motor housing, and cause motor failure. If the following examples occur, high performance filter is not loaded correctly. Reload them correctly to rectify problem.

### Problem Examples

Securing lip of high performance filter is not firmly locked into groove of cleaner housing.

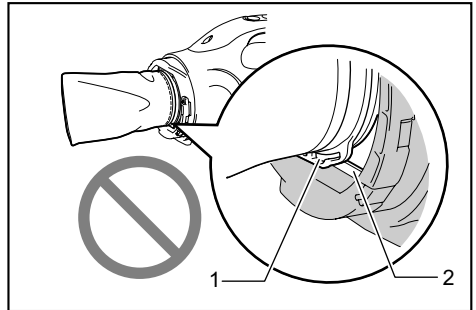

► 1. Securing lip 2. Groove of cleaner housing

## OPERATION

**CAUTION:** To connect attachments, such as nozzle, twist and insert the attachment in direction of the arrow to secure the connection during use. To disconnect the attachments, twist and extract it also in direction of the arrow. If an attachment is twisted in the opposite direction when being connected or disconnected, the capsule may become loose.

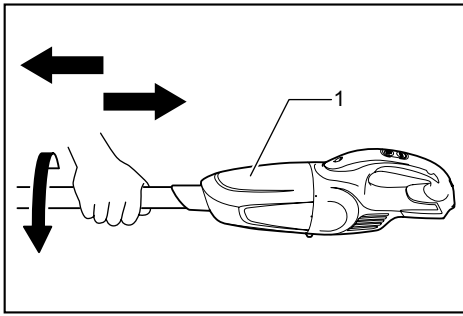

► 1. Capsule

## Cleaning (Suction)

### Nozzle

Attach the nozzle to clean off tables, desks, furniture, etc. The nozzle slips on easily.

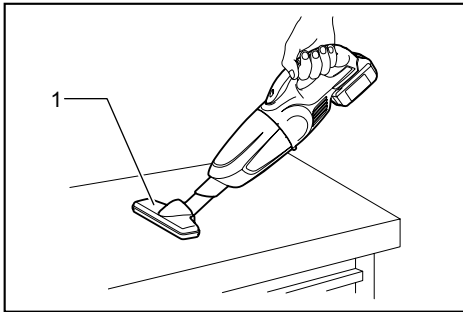

► 1. Nozzle

### Nozzle + Extension wand (Straight pipe)

The extension wand fits in between the nozzle and the cleaner itself. This arrangement is convenient for cleaning a floor in a standing position.

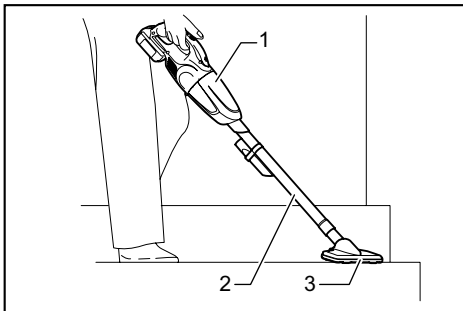

► 1. Cleaner body 2. Extension wand 3. Nozzle

### Corner nozzle

Fit on the corner nozzle for cleaning corners and crevices of a car or furniture.

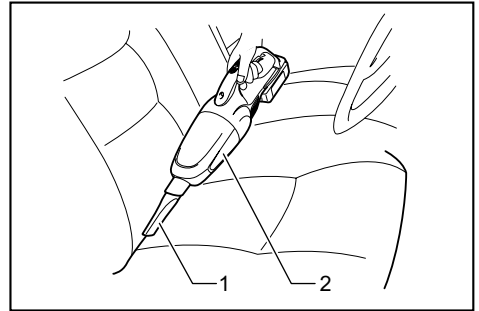

► 1. Corner nozzle 2. Cleaner body

### Corner nozzle +Extension wand (Straight pipe)

In tight quarters where the cleaner itself cannot squeeze in, or in high places hard to reach, use this arrangement.

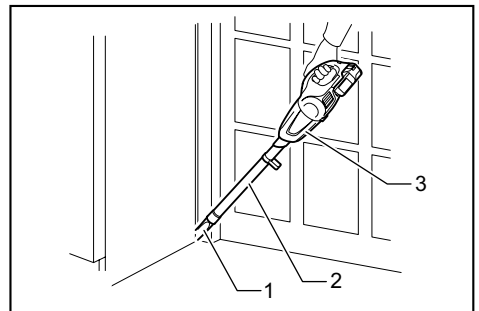

► 1. Corner nozzle 2. Extension wand 3. Cleaner body

### Cleaning without nozzle

You can pick up powder and dust without nozzle.

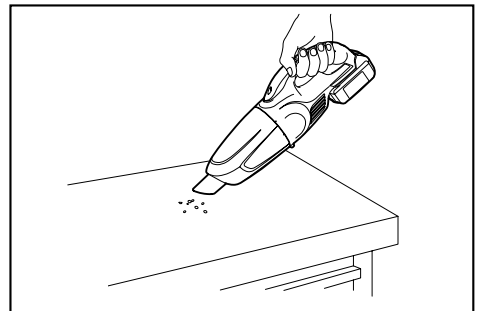

# MAINTENANCE

**CAUTION:** Always be sure that the tool is switched off and the battery cartridge is removed before attempting to perform inspection or maintenance.

**NOTICE:** Never use gasoline, benzine, thinner, alcohol or the like. Discoloration, deformation or cracks may result.

## After use

**NOTICE:** Putting the cleaner against the wall without any other support cause the cleaner to fall down and be damaged.

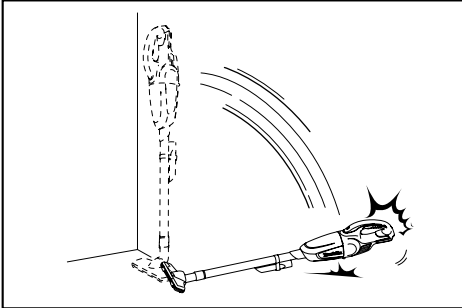

## Cleaning

From time to time wipe off the outside (cleaner body) of the cleaner using a cloth dampened in soapy water.

Clean out also the suction opening, dust bag/paper filter mounting area and the dust stopper.

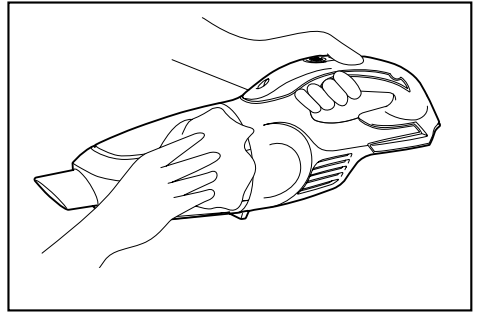

Wash the filter in soapy water when it is clogged with dust and the cleaner power becomes weak. Dry it out thoroughly before use. An insufficiently dried filter may cause poor suction and shorten the service life of the motor.

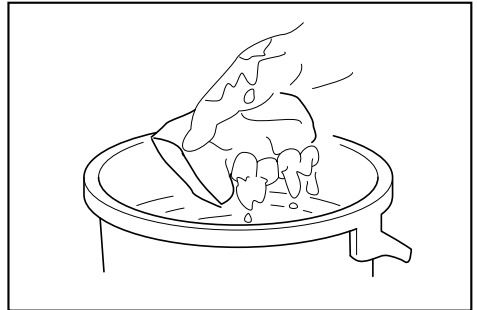

## Troubleshooting

Before asking for repairs, check the following points.

Symptom	Area to be investigated	Fixing method
Weak suction power	Is the capsule full of dust?	Empty the capsule of dust.
	Is the filter clogged?	Clean or wash the filter.
	Is the battery cartridge exhausted ?	Charge the battery cartridge.
Not working	Is the battery cartridge exhausted ?	Charge the battery cartridge.

**CAUTION:** Do not attempt to repair the cleaner by yourself.

To maintain product SAFETY and RELIABILITY, repairs, any other maintenance or adjustment should be performed by Makita Authorized or Factory Service Centers, always using Makita replacement parts.

# OPTIONAL ACCESSORIES

**CAUTION:** These accessories or attachments are recommended for use with your Makita tool specified in this manual. The use of any other accessories or attachments might present a risk of injury to persons. Only use accessory or attachment for its stated purpose.

If you need any assistance for more details regarding these accessories, ask your local Makita Service Center.

- Extension wand (Straight pipe)
- Nozzle
- Nozzle for carpet
- Shelf brush
- Corner nozzle
- Round brush
- Flexible hose
- Free nozzle

- Filter
- Prefilter
- High performance filter
- Makita genuine battery and charger

**NOTE:** Some items in the list may be included in the tool package as standard accessories. They may differ from country to country.

**Makita Europe N.V.** Jan-Baptist Vinkstraat 2,  
3070 Kortenberg, Belgium

**Makita Corporation** 3-11-8, Sumiyoshi-cho,  
Anjo, Aichi 446-8502 Japan

[www.makita.com](http://www.makita.com)

885580-221  
EN  
20161207